

Economical.
Repeatable.

Amerimade Technology

A name that means quality

All of Amerimade's wet processing equipment is designed and engineered for safety, ease of use and low cost of ownership.

Ameri...quality.

Ameri...service.

Amerimade.

Recirculating Tank

Pump Filter Recirculating Tank

Temperature range from 0° to 165° C with various types of temperature control. Amerimade's PF Series baths are designed for cleanliness.

The solution is pumped directly from the filter to the inner tank where the wafers are located.

It then travels over the temperature control loop to the pump and filter. This system filters the acid 4 to 6 times per minute.

The filter bath may be completely insulated for extremely high or low temperature, and a secondary containment shell is available.

Other options include: flow sensor, flow control valve, liquid level sensor, and secondary over-temperature shut-off device.

Available Materials

Natural polypropylene

PVDF

Teflon®

Stainless Steel



★AMERIMADE
Technology Inc.

1 800 WET ETCH

www.amerimade.com

Amerimade PF Tank Dimensions

Model Number	Xfer Arm	Carrier Capacity	Flange Width	Flange Depth	Inside Width	Inside Depth	Deck Cut-out Width	Deck Cut-out Depth	Liquid Level	Capacity (Gallons)	Tank Height	Shroud Height	Description
			A	B	C	D	E	F	W		G		
PF41/51/61		1 x 6"	17.50	12.50	8.00	8.00	15.75	10.75	7.50	6.00	18.00	11.00	Pump Filter
PF42		2 x 4"	21.00	12.00	11.50	7.50	19.25	10.25	5.50	5.50	16.00	11.00	Pump Filter
PF52		2 x 5"	23.50	12.00	14.00	7.50	21.75	10.25	6.50	7.00	16.00	11.00	Pump Filter
PF62		2 x 6"	25.50	12.50	16.00	8.00	23.75	10.75	7.50	9.00	18.00	11.00	Pump Filter
PF81		1 x 8"	20.50	15.50	11.00	11.00	18.75	13.75	9.50	11.00	20.00	11.00	Pump Filter
PF82		2 x 8"	31.00	15.50	21.50	11.00	29.25	13.75	9.50	18.00	20.00	11.00	Pump Filter
PF41/51/6	AT	1 x 6"	18.50	13.50	9.00	9.00	16.75	11.75	8.50	8.00	19.00	11.00	Pump Filter for Transfer Arm
PF42	AT	2 x 4"	22.00	13.00	12.50	8.50	20.25	11.25	6.50	7.00	17.00	11.00	Pump Filter for Transfer Arm
PF52	AT	2 x 5"	24.50	13.00	15.00	8.50	22.75	11.25	7.50	9.00	17.00	11.00	Pump Filter for Transfer Arm
PF62	AT	2 x 6"	26.50	13.50	17.00	9.00	24.75	11.75	8.50	11.00	19.00	11.00	Pump Filter for Transfer Arm
PF81	AT	1 x 8"	21.50	16.50	12.00	12.00	19.75	14.75	10.50	13.00	21.00	11.00	Pump Filter for Transfer Arm
PF82	AT	2 x 8"	32.00	16.50	22.50	12.00	30.25	14.75	10.50	21.00	21.00	11.00	Pump Filter for Transfer Arm

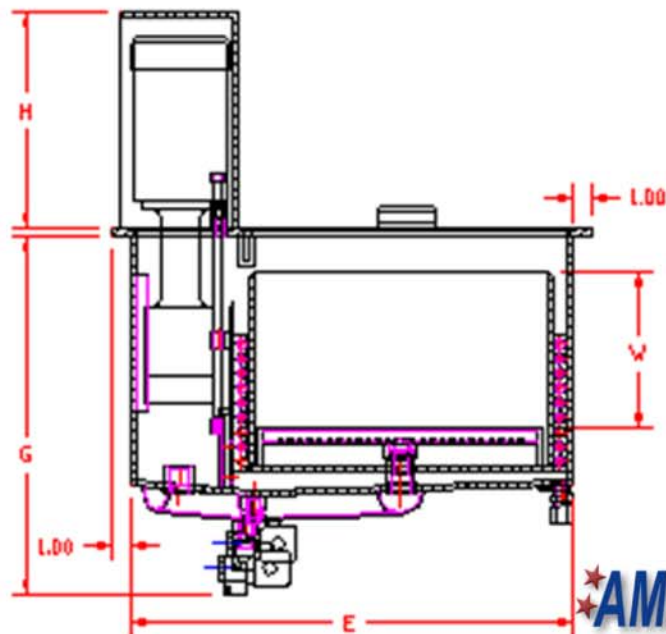
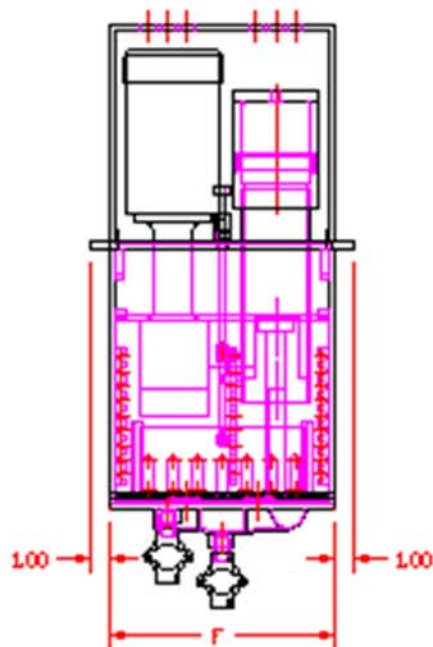
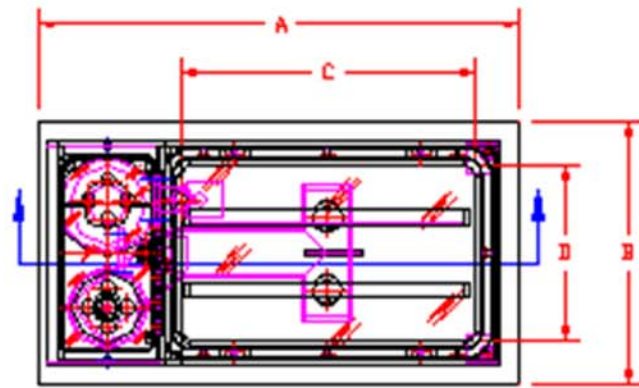

AMERIMADE
Technology Inc.

1 800 WET ETCH

www.amerimade.com